



## **Industrial Technology**

**Stage 5 - Year 10**

**Step Stool**



# Contents

1. Rationale .....	3
2. Description of project.....	3
3. Materials .....	4
4. Cutting list and Costing .....	5
5. Construction Process .....	6
6. Engineering Drawings .....	7

## 1. Rationale

The purpose of this project is to design, develop and construct a project from a set of specifications. Students are to complete design research. This will hopefully allow greater understanding of the purpose of the project as well as the design and construction methods selected.

Design development resulting in individualisation of project is encouraged. An accompanying Portfolio will document all of these processes.

## 2. Description of project

The step stool is a useful item designed to be used around the home. This project is designed to be taken home by students and used practically around the home, it will be a visual reminder in years to come, of the usefulness the Stage 5 Industrial Technology course was. It also allows family member to see, use and appreciate something that you made.

The step stool is simple in construction but employs many of the techniques use is larger projects. This is helpful for those students looking a completing Industrial Technology or Design and Technology in Stage 6. Widening Joints, housing joints and routed edge detailing are all elements of the project.

### 3. Materials

Radiata Pine is native to the central coast of California but is widely planted in Australia and New Zealand. It makes up 28% of Tasmania's timber plantations and is an environmentally sustainable softwood popular in all types of construction and decorative uses. These include framing, lining, glue laminated beams, veneer and plywood. It can be used for many exposed structural and non-structural applications if it is treated with the right preservatives.

The texture of Radiata Pine is fine, but uneven, and knots are common. The timber is fairly soft and has a low density, often with very wide annual growth rings. The sapwood is white to pale yellow, but often indistinguishable from the heartwood, which is light brown to yellow. The grain is usually straight, apart from a central core of 100mm, which can twist if the moisture content of the timber changes.

Radiata Pine is easy to work, apart from the knots, and it readily accepts preservatives.

#### 4. Cutting list and Costing

<b>Item</b>	<b>Timber size (mm)</b>	<b>Length (mm)</b>	<b>Quantity</b>	<b>\$ per meter</b>	<b>Cost (\$)</b>
<b>Side</b>	190 x 19	600	2	\$ 6.22	\$ 7.47
<b>Lower step</b>	190 x 19	400	2	\$ 6.22	\$ 4.98
<b>Upper step</b>	190 x 19	400	1	\$ 6.22	\$ 2.49

## 5. Construction Process

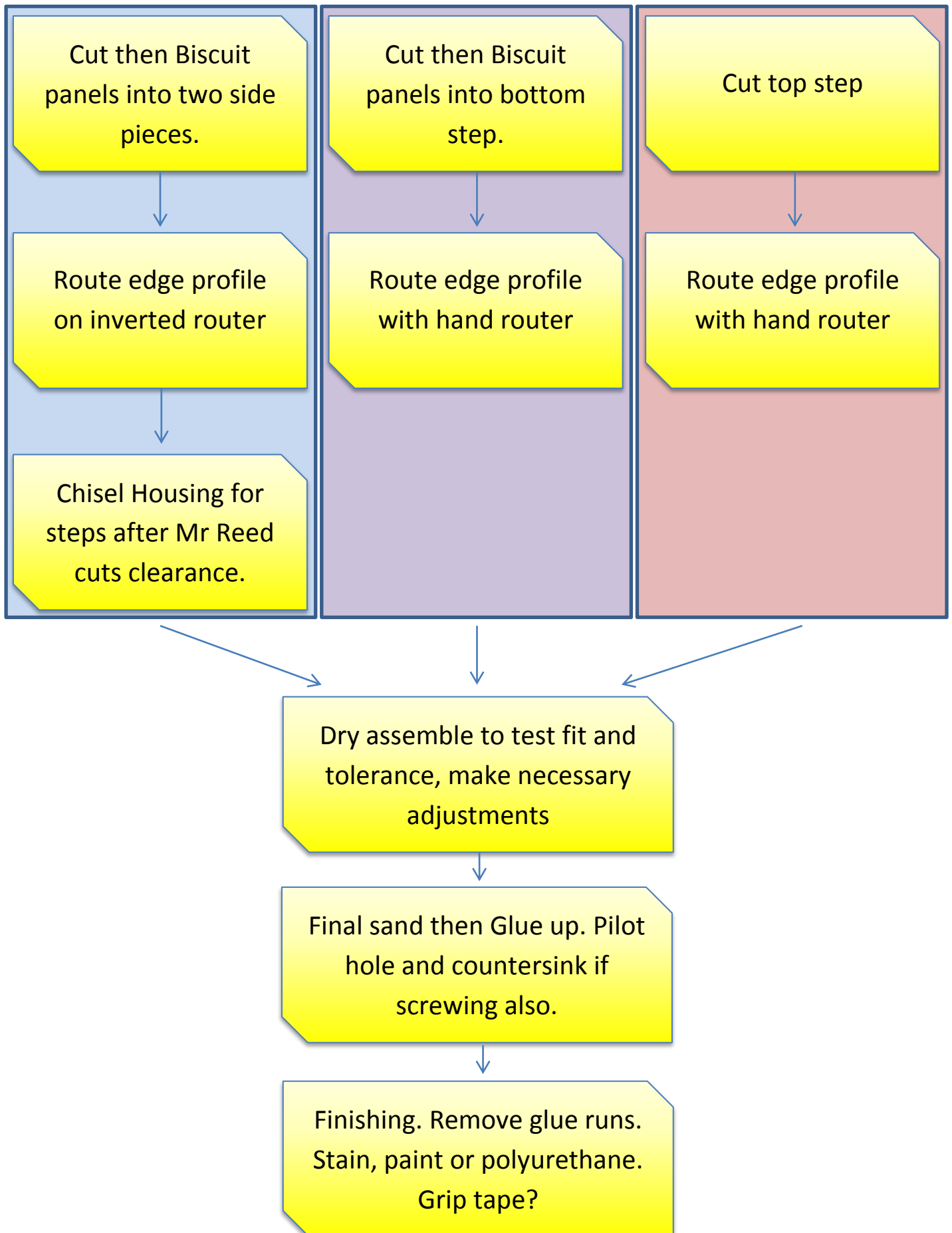

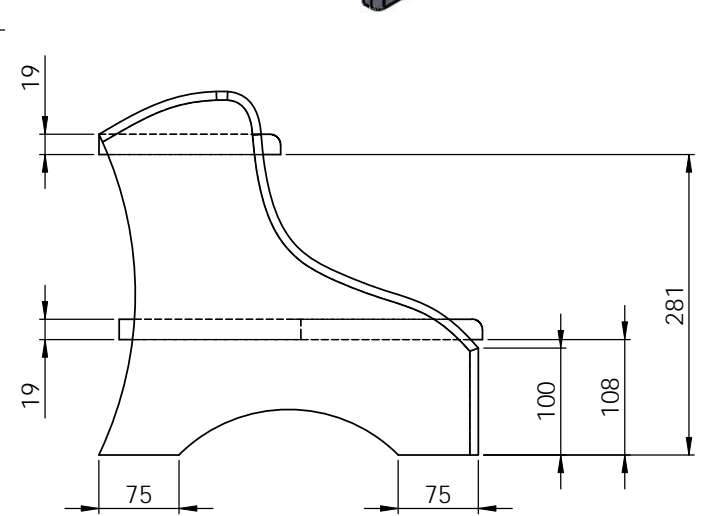
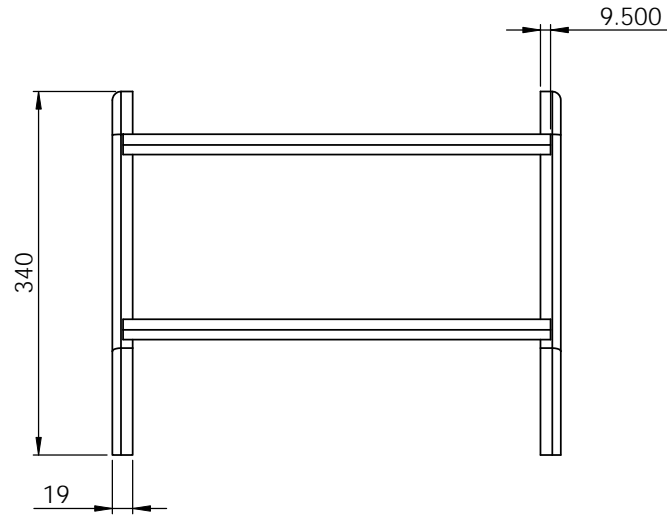
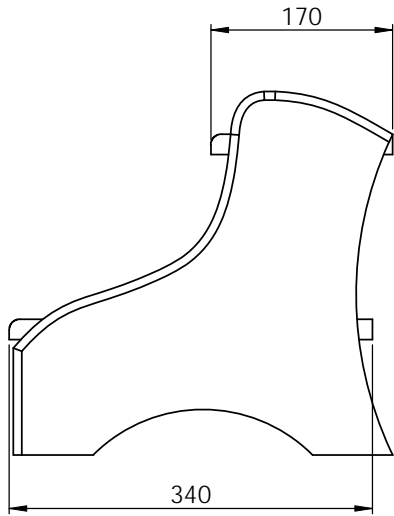
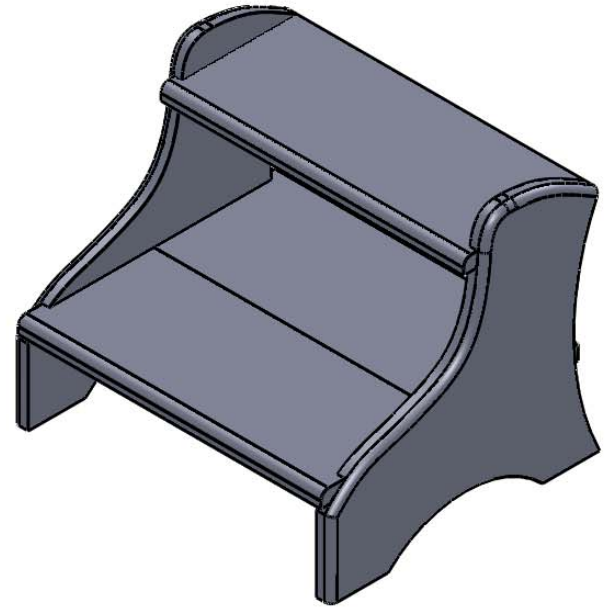
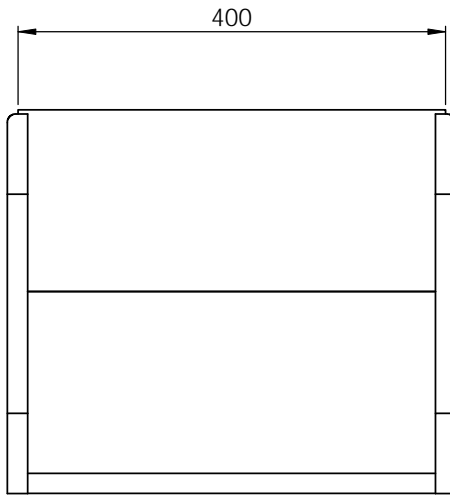
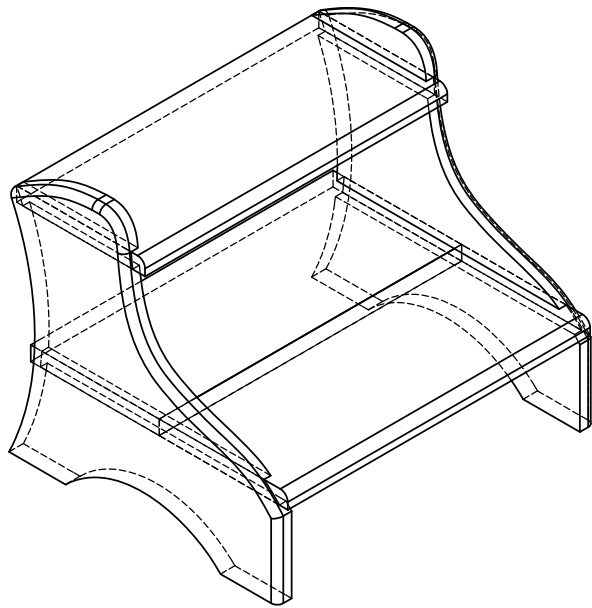

UNLESS OTHERWISE SPECIFIED: DIMENSIONS ARE IN MILLIMETERS				FINISH:		DEBUR AND BREAK SHARP EDGES		DO NOT SCALE DRAWING		REVISION	
SURFACE FINISH:											
TOLERANCES:											
LINEAR:											
ANGULAR:											
DRAWN		NAME		SIGNATURE		DATE		TITLE:			
CHK'D		Mr Reed									
APP'VD											
MFG											
Q.A								MATERIAL:		DWG NO:	
										Stool Dimensions	
								WEIGHT:		SCALE:1:5	
										SHEET 1 OF 1	
										A3	